

LIFTMOORE 3612REE 7-15 CRANE

12,000 FT.-LB. MOMENT RATING
3,600 LB. MAXIMUM CAPACITY

The Model 3612REE 7-15 is the latest model added to our product line. This unit comes standard with power features for maximum operation ease. Power boom elevation allows remote control of the boom angle, Power rotation makes handling heavy loads safer. Power hoist makes for accurate lifting and setting of objects. Hydraulic power boom extension from 7-11 with a manual pull out to 15' is standard.

Contact Liftmoore for other boom configurations.

Standard Color is Liftmoore White:



Sheave meets ANSI Standard

Anti Two-Block

1/4" GAC

Traveling Block w/hook & Safety Latch. Meets ANSI Standards

Power extension 7-11' w/ 4' pull out to 15'

Power Boom Elevation

Planetary Gear Winch

Model 3612

Electric Hydraulic Pump

Rotates on Tapered Roller Bearings

Hydraulic Powered Rotation

LOAD CAPACITY - LBS. 12,000 FT-LBS

BOOM LENGTH - FT.	LOAD CAPACITY - LBS.					
	0°	15°	30°	45°	60°	75°
7	1714	1774	1979	2424	3428	3600
9	1333	1380	1539	1885	2666	3600
11	1090	1129	1259	1542	2181	3600
13	923	955	1065	1305	1846	3566
15	800	828	923	1131	1600	3090



HOUSTON, TEXAS
FAX: (800) 824-5559 (USA & Canada)
FAX: (713) 688-6324
PHONE: (713) 688-5533
www.liftmoore.com

713-688-5533
WWW.LIFTMOORE.COM

24344

3612REE 7-15 SPECIFICATIONS

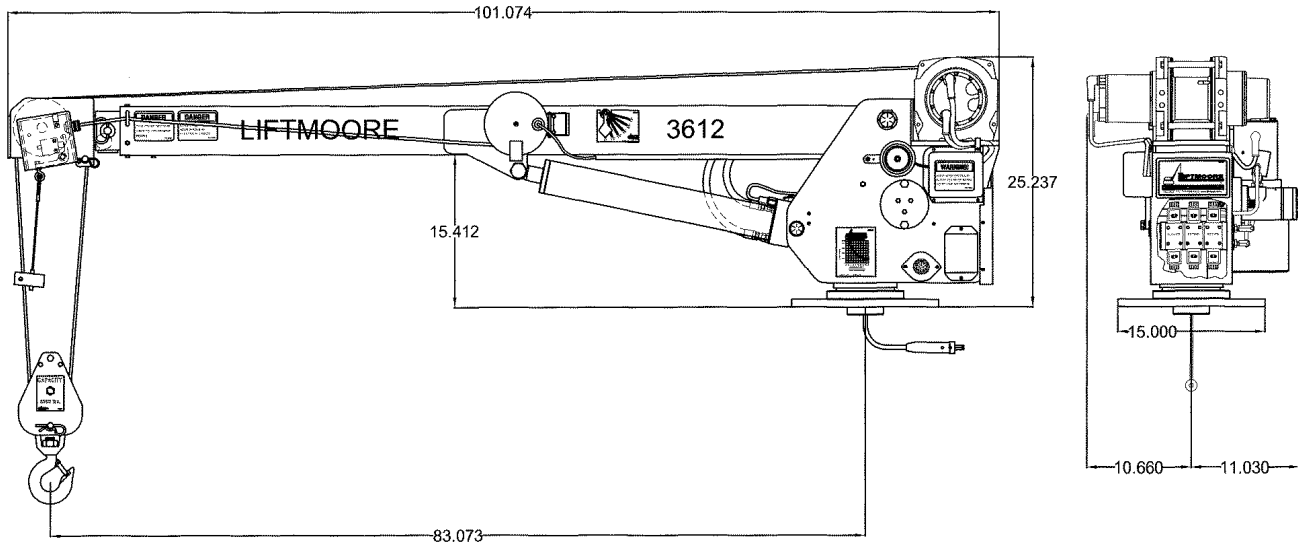

MOMENT RATING: 12,000 Ft.-Lbs.

HOIST WINCH: The hoist winch has a planetary gear drive for best possible efficiency. A 2.7 HP permanent magnet electric motor powers the winch. Single line capacity of the winch is 2000 Lbs. Load is controlled by a load apportioned mechanical brake located in the winch drum. Ratio between winch drum and wire rope meets ANSI B30.5 requirements.

First layer performance of the winch is as follows:

Load-Lbs	Hook Speed-Ft/ Min.	Electrical-Amps @ 12VDC
1000	13.1	64
2000	11.9	115

Note: Two part line required for loads above 2000Lbs.

WIRE ROPE and SHEAVES: The crane is supplied with 62 Ft. of ¼ in. galvanized aircraft cable. Minimum breaking strength of the rope is 7000 lbs. The wire rope is outside of the boom and visible for operators continual inspection. A traveling block for easy two-part hookup is included. All sheaves meet ANSI requirements.

BOOM: The boom is capable of moving from -5 to +75 Degrees. A double acting cylinder with an integral counterbalance elevates the boom. The counterbalance valve has two important functions. This valve holds the cylinder in the event of hose failure and it controls the rate of boom decent.

The boom extends under power from 7 Ft. to 11 Ft. with a 4 Ft manual pull out to 15 Ft. with one intermediate position at 13 Ft.

Contact Liftmoore for other boom configurations.

HYDRAULIC SYSTEM: A hydraulic pump driven by a 12 volt D.C. series wound electric motor powers the crane's rotation, elevation and extension functions. Pump is a gear type with a 1.3 GPM capacity at 500 PSI. Control of the hydraulic functions is through four way spring centered solenoid activated valves. Valves have manual over-ride capability and are mounted on a manifold for easy access.

ROTATION SYSTEM: The hydraulic powered rotation is driven by a low speed, high torque hydraulic motor. The crane rotates 360 degrees continuously without limit on two 3.75" ID Tapered roller bearings.

REMOTE PENDANT CONTROL: An 18-Ft. long remote pendant is provided for control of each powered function. The Pendant control is removable from the crane to prevent unauthorized use of the crane. An E-Stop is included for emergency shutdown of all crane power as required by OSHA. **Optional** Wireless control is available.

LOAD SENSOR: A load-limiting sensor is supplied as standard. This sensor will shut down hoist up, boom out & boom down when an overload is detected. The sensor will reset after the load is lowered.

ANTI TWO-BLOCK: A standard on this crane, prevents extending the boom against the travel block and breaking the cable.

POWER SOURCE: Crane is powered by the truck's 12 volt DC system. A second battery is required to keep the voltage as high as possible and should be installed in parallel with the vehicle's battery. A Group 31 "DEEP CYCLE" battery is recommended. 25 Ft of #1 battery cable with quick disconnect is included along with a 3-ft ground wire, 150amp circuit breaker and master cut off switch.

MOUNTING: An 11,000-Lb or larger GVWR chassis is recommended. Four 0.50" X 3.0" long Grade 8 hex head cap screws and lock nuts are provided. Mounting plate is 15" square with a 12" square bolt pattern.

OUTRIGGERS: An optional outrigger is needed for stability requirements of OSHA 1910.180. The Outrigger is necessary to reduce the load on the crane's rotation mechanism and the truck's suspension.

BOOM REST: A boom rest is required on all Power rotation Model Cranes.



HOUSTON, TEXAS
 FAX: (800) 824-5559 (USA & Canada)
 FAX: (713) 688-6324
 PHONE: (713) 688-5533
 www.liftmoore.com