

HOUSTON, TEXAS WWW.LIFTMOORE.COM
PHONE: (713) 688-5533 • FAX: (713) 688-6324
FAX: (800) 824-5559 (USA & CANADA)

Installation Instructions

Model 5080 Series

P/N 22428

! ATTENTION!

KEEP THIS MANUAL WITH THE CRANE. OPERATION INSTRUCTIONS ARE CONTAINED IN A SEPARATE MANUAL. NEW OPERATORS SHOULD READ AND BE FAMILIAR WITH THE OPERATING INSTRUCTIONS BEFORE OPERATING THIS CRANE.

ORDER PARTS USING PART NUMBER, CRANE MODEL NUMBER AND CRANE SERIAL NUMBER TO ASSURE ACCURACY OF ORDERS.

MODEL 5080 INSTALLATION INSTRUCTIONS

TABLE OF CONTENTS

Crane Installation Instructions.....	F925-F.....	2-3
Mounting Pattern	DWG. 50169-C.....	4
Electrical Installation.....	DWG. 50378-A.....	5
Hydraulic Installation.....	DWG. 50026-A.....	6
Engine Control Receiver Installation.....	F1214-B.....	7
Stability Procedure.....	F691-D.....	8-9
Stability Test Results.....	DWG. 50562-B.....	10



MODEL 5080 INSTALLATION INSTRUCTIONS

Read and understand these instructions completely before starting the work.

Before installing make sure you have all necessary parts. Please refer to the Owner's manual Section 4-1 for the list of parts required for installation. Report any shortages to Liftmoore, Inc. immediately.

1. The mounting surface for the crane must be capable of supporting the rated moment and the maximum load of the crane listed below:

5080: 50,000 Ft.-Lbs. 8000 Lbs.

2. Layout the mounting holes for the crane as shown in the drawing No. 50169. Cut the center hole for the crane swivel as shown on this drawing. Mount the crane with four 1" bolts of at least Grade 8 quality.

3. A manual disconnect switch with mounting bracket and terminals is provided with the crane. This switch will act as the main power disconnect for the crane. Removing power from the crane during periods of non-use will help to increase the life of the crane's electrical components. The switch should be mounted as near as possible to the crane and in a position which will facilitate its use. Determine the appropriate mounting position for the switch and use the supplied terminals to splice in to the crane's main power cable. Drawing No. 50378 illustrates how to install the disconnect switch and fuse.

4. Install the 30 Amp fuse, which is supplied with the crane, near the battery on the positive line. This fuse is to protect the wiring in event of an accidental grounding. Use a section of the wire and the terminals supplied to connect between the battery and the circuit breaker. See drawing No. 50378.

5. Run the 10 Ga. battery cable along the inside of the chassis frame to the positive battery terminal and connect it to the battery through the in-line fuse. See that the cable is protected. Avoid sharp edges and heat sources such as the muffler or catalytic converter. Use loom for protection whenever the cable passes through the body. On continuous rotation models, use the terminal supplied and connect the cable to the bolt located between the pipe nipples in the center of the swivel under the crane. On limited rotation models connect the battery wire to the 10 gage black wire under the crane.

6. Be certain that the crane and the battery are grounded to the truck chassis. A good ground must exist for the crane to work.

7. Hydraulic Component Installation: The following description applies to Liftmoore's Hydraulic Installation Drawing No. 50026.

These cranes require a pump driven by the vehicle's engine. Pumps can be either Power Take Off or Fan Belt drive. For best, smoothest operation the pump needs to supply 6 GPM at 3000 PSI with the engine at 1000 RPM. An example of this pump is Muncie's PK6. At 600 RPM it delivers 3.5 GPM and at 1000 RPM it delivers 6 GPM.

Do not use pumps that will deliver more than 6 GPM at engine speed. 10 GPM is the maximum flow acceptable to the valves in the crane. If a larger pump is installed on the vehicle for other functions, use a pressure compensated flow control valve to restrict the flow to the crane as required above.

A wire control or solenoid throttle advance can be used to increase the engine speed. Liftmoore can supply a solenoid throttle advance kit (Part No. 32592) that includes a control switch to be mounted near the crane. On engines with electronic throttles, the solenoid throttle advance cannot be used, check with the dealer for throttle advance information. Engine speed, start and stop control can be included in the pendant control box if ordered.

A reservoir of at least 10 gallon capacity is recommended. Reservoir capacity will need to be enlarged for increased running time. For run times of 15 minutes or less the 10 gallon capacity is adequate. For longer duty cycles the reservoir size should be increased.



MODEL 5080 INSTALLATION INSTRUCTIONS, Cont.

The reservoir should be equipped with a suction line strainer, return line diffuser, and filler/breather cap. A sight gage for displaying fluid level is also advisable. Locate the reservoir as close to the pump as possible and as high as possible above the pump.

A relief valve should be installed at the pump's output to protect the pump from pressure surges. The crane incorporates a relief valve to protect its valves and hoses.

For up to 9.5 GPM flow the minimum suction line hose size is 1" ID. For the pressure line a 5/8" ID hose is needed. For the return line between the crane and reservoir a 3/4" ID is advised. Hose sizes can be reduced for lower flows.

A 10 Micron return line filter should be installed in a location that allows convenient access to the replaceable cartridge.

8. DO NOT RUN OIL THROUGH THE CRANE UNTIL THE OIL HAS BEEN FILTERED. An adapter union matching the crane fittings is included. Connect the supply and return lines together using this adapter, circulate the oil through the filter to insure a clean supply. After the pump has filtered 1.5 times the reservoir capacity, hook the hoses to the crane. It is now ready to run.

9. Connect the hydraulic hoses to the fittings projecting below the crane. The pressure hose must be connected to the port marked "P" (No. 8 size fitting). This is the smaller of the two fittings. The return line to the tank must be connected to the port marked "T" (No. 10 fitting). This is the larger of the two fittings. The port letters are stamped on the bottom of the swivel.

10. Verify that the anti two-block will stop extension out and winch up when the weight on the device is lifted by either function. Make sure that the weight is on the live or running wire rope. The Crane Assembly drawing in the owner's manual Section 4-2 illustrates how the weight should be installed on the line.

11. READ AND UNDERSTAND OPERATORS MANUAL BEFORE OPERATING CRANE. Operate the crane through all its functions. Check that each switch operates the correct function. Verify speed of the unit.

12. A boom support is required for this crane. For bodies shorter than 132", place the support so that the traveling block hook is secured and does not block the truck cab door. On boom rests supplied by Liftmoore the boom is held down by tension on the hoist wire rope.

13. An outrigger must be installed to keep the crane as level as possible under all expected working conditions. Keeping the crane level reduces the loads on the rotation gear. This will also protect the truck's springs, axle and wheels when heavy loads are suspended from the crane. OSHA requirements require a stability test be performed on this installation.

15. Extra rear spring leaves or heavy coil springs may be needed to keep the truck level when the crane is mounted on corner or off center locations.

16. Place these instructions with the Operators Manual.

17. Load Chart Decal Load Chart # 22381 for the 5080 is to be placed on the truck body for easy visibility by the user.



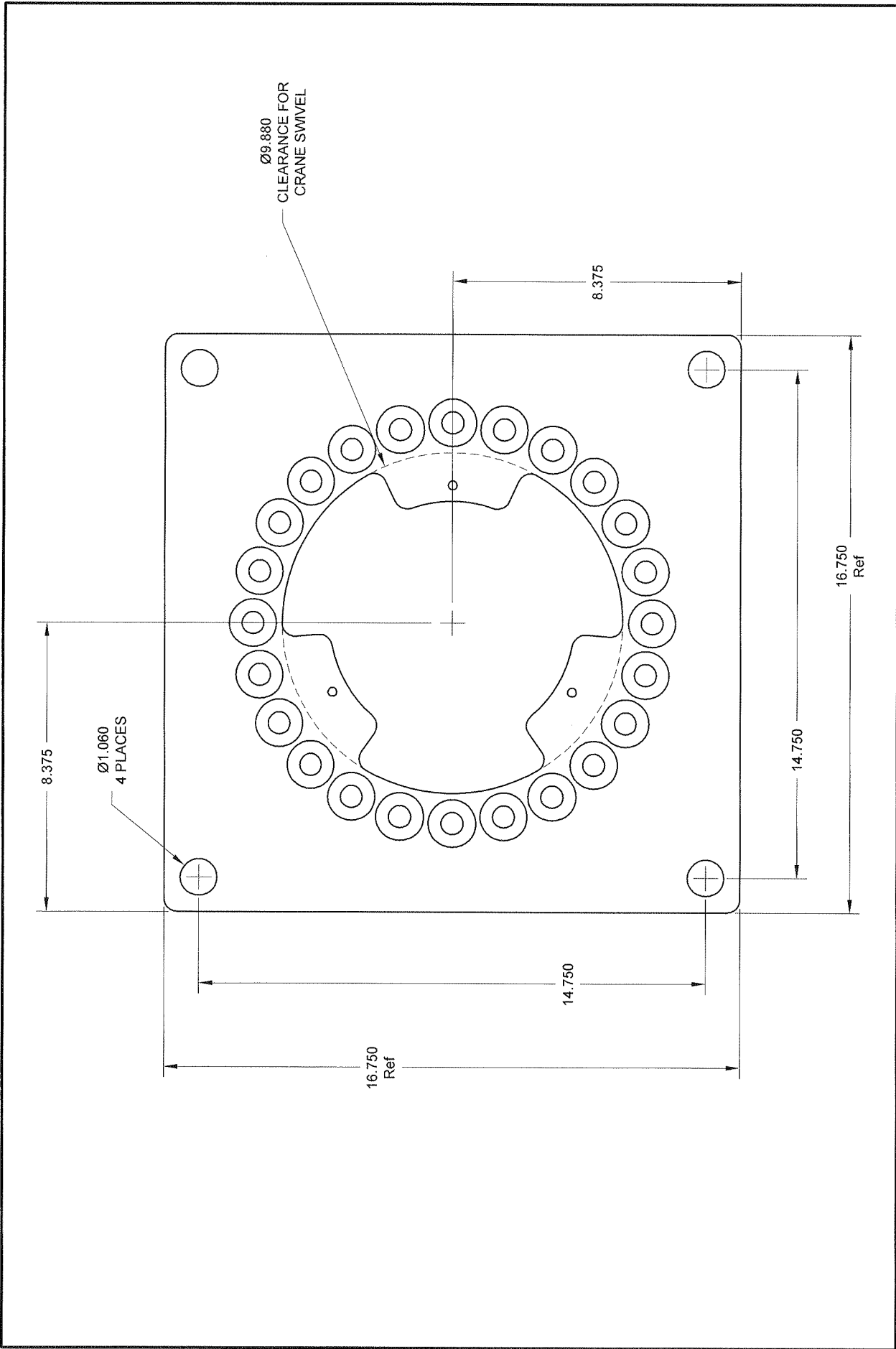

DRAWING NO. 50169-C

BASE PLATE 5080

DRWN BY: JC
DATE: 3/30/07

Houston TX
(713)-688-5533
www.liftmoore.com



SUGGESTED WIRING SCHEMATIC FOR LIFTMOORE HYDRAULIC CRANE INSTALLATION

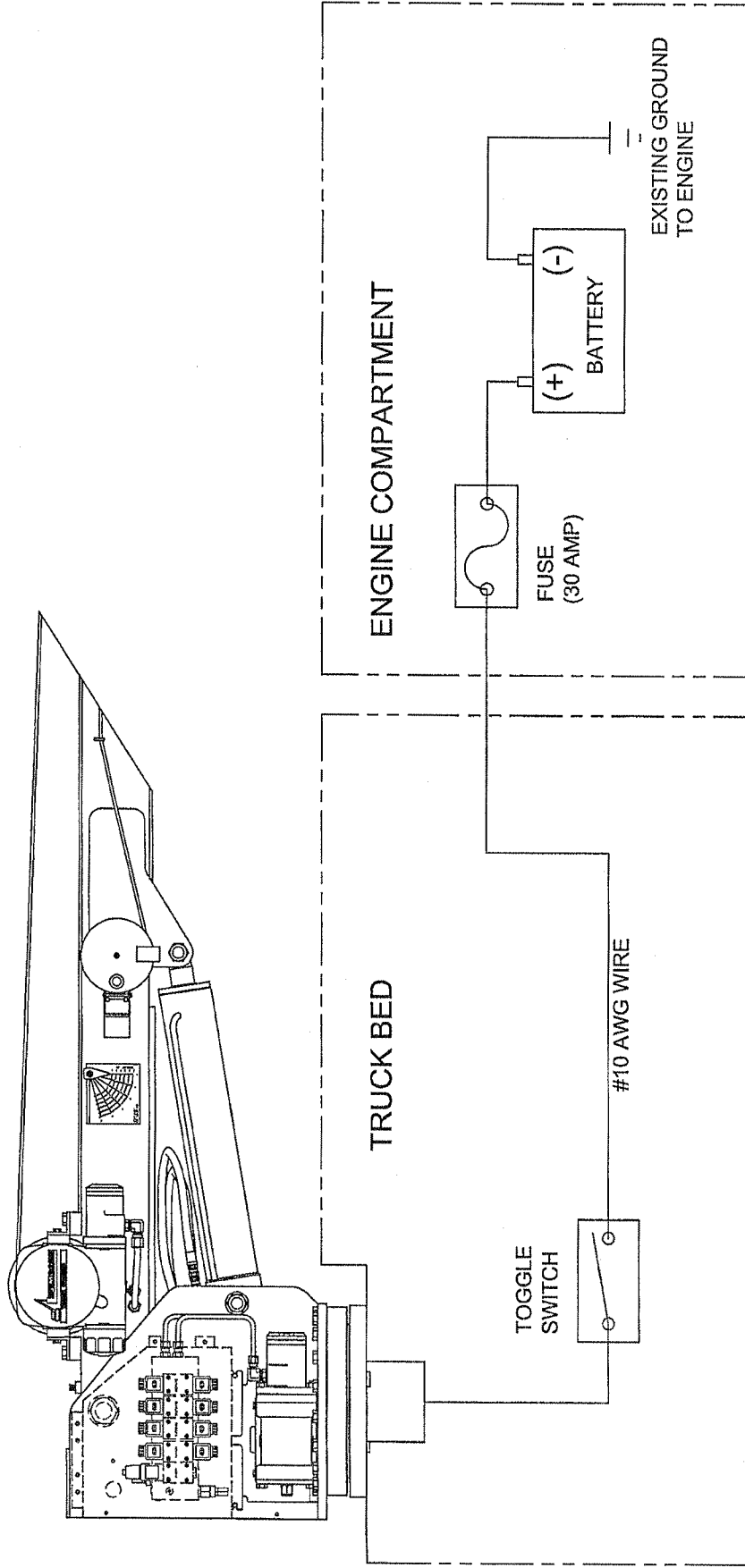

Houston TX
(713)-688-5533
www.liftmoore.com

DRWN BY: TV

DATE: 03/02/06

SCHEM, CRANE ELEC. INSTAL-HYDR

DRAWING NO.

50378-A



SUGGESTED HYDRAULIC SCHEMATIC FOR LIFTMOORE HYDRAULIC CRANE INSTALLATION

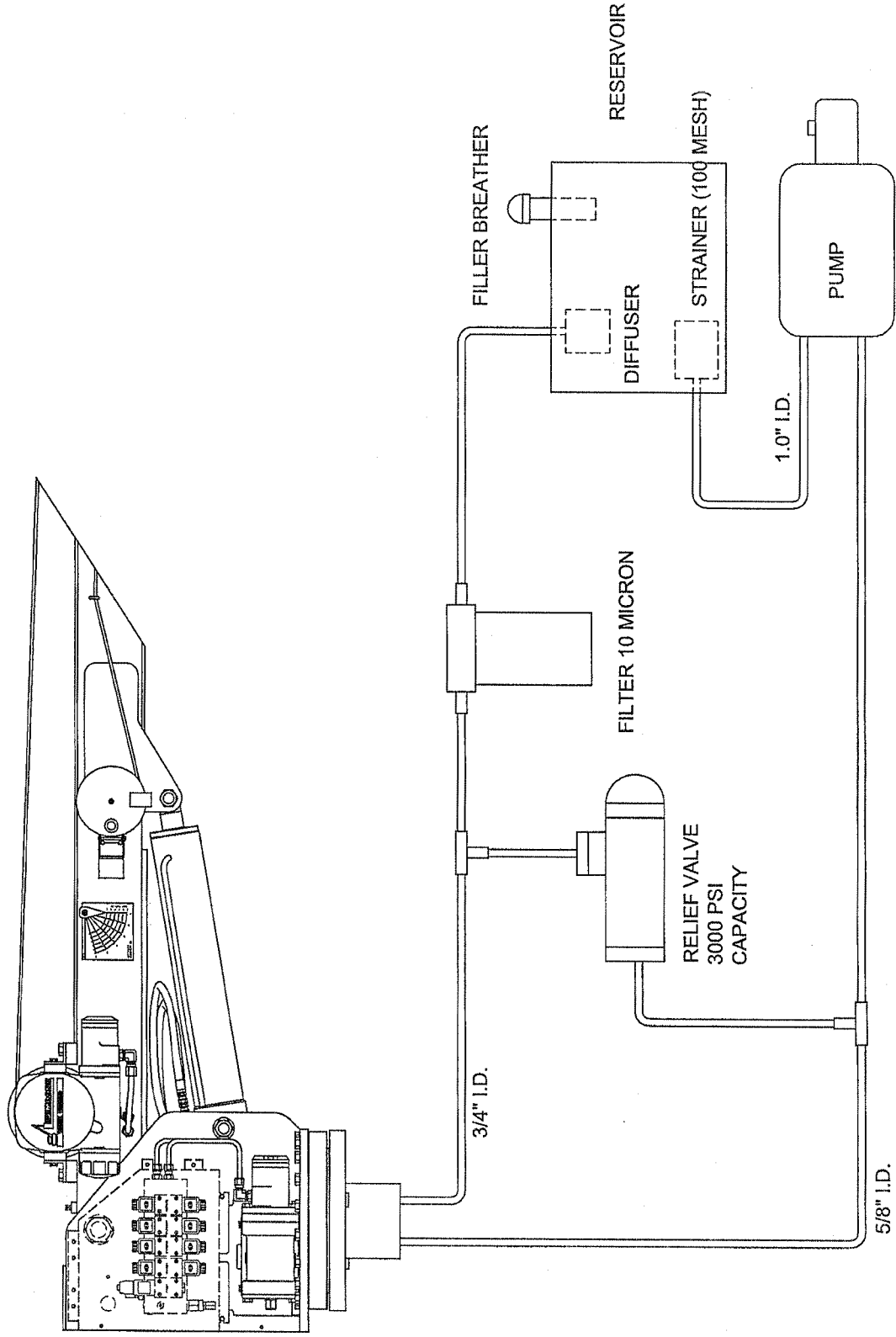

DRAWING NO.
50026-A

SCHEM, CRANE HYD. INSTAL-HYD

DRWN BY: TV

DATE: 03/02/06

Houston TX
(713)-688-5533
www.liftmoore.com



OPTIONAL ENGINE CONTROL RECEIVER INSTALLATION

The engine control functions allow the user to start and stop the engine and also advance the idle, all from the crane remote pendant control.

The following instructions provide a general guideline for installing and wiring the receiver. Since engine controls vary from manufacture to manufacturer and even from year to year, it is impossible for Liftmoore to maintain specific information on your vehicle. You will have to contact the vehicle and/or engine manufacturer (contact information is provided below). Also, many new vehicles have a provisions for remote engine control built into the ECU, but these functions must be activated and/or programmed buy a dealer or authorized service center.

MOUNTING THE RECEIVER

The receiver should be mounted vertically with the antenna up. For best reception, it should be mounted in line of site of operator. Since interfacing connections will generally be inside the cab, a good mounting place is the inside, back the cab with the antenna visible though the back glass. The receiver can be mounted outside of the cab, however it should NOT be mounted inside the engine compartment because of interference generated by the engine.

ENGINE START

Engine start is accomplished by splicing the brown wire on the engine receiver control harness with the ECU start circuit.

WARNING!

Engine start may bypass some manufactures safety functions such as clutch or neutral interlock. It is the installer's responsibility to ensure safe and proper installation.

ENGINE STOP

If the ECU is not equipped with a remote engine kill circuit then a normally closed relay must be installed in the ECU power or engine run circuit. The gray wire on the engine control receiver harness is then connected to the solenoid coil. Activating the circuit will open the solenoid, killing the engine.

NOTE!

It is advisable to include a small jumper wire that can be installed to bypass the solenoid should it fail, otherwise the engine would not run.

ADVANCED IDLE

Many new diesel engines have an advanced idle control circuit built into to the ECU. Some automatically advance the idle when the PTO is activated. This feature may have to be activated and/or programmed by the dealer.

NOTE!

Some engines also require activating a PTO circuit to prevent "Service Engine Soon" or other erroneous errors during PTO operation.

For gas engines or engines without this feature, an after-market throttle advance will have to be purchased separately.

CONTACT INFORMATION

Your truck or engine dealer should be able to provide you with further assistance. Also check the manufacturer's body builder manual (some provided online). Before calling, please have your vehicles make, model, year, engine size and manufacturer, and VIN if available.

Ford Body Builders Advisory Service	1.877.840.4338
GM Upfitter Integration	1.800.875.4742
Peterbilt	1.940.591.4000
Caterpillar	1.800.847.4986
Cummins	1.800.343.7357

www.fleet.ford.com/truckbbas
www.gmupfitter.com



CRANE STABILITY TEST

This test is designed to fulfill the requirements of SAE J765. The test insures that under normal working conditions the truck will not exceed 85% of its tipping capacity. In order for the truck to remain within this recommended 85% tipping capacity, a load equal to 118% of the crane's rated capacity must be used for this test.

Test Preparations:

- 1) SAE J765 requires that the testing surface must be level to within 1%. It is recommended that the test be conducted on a flat concrete surface.
- 2) Position outriggers so that the weight of the crane is removed from the truck springs.
- 3) Rotate the crane so that it is extended over the rear of the truck (Refer to Drawing 50562). Extend the boom completely.
- 4) DETERMINE REQUIRED LOAD RADIUS:

Elevate the boom to between 20 and 45 degrees. At this elevation the crane's overload system should not trip.

Measure the load radius "L". This is the distance from the center of rotation to the load line measured parallel to the ground.

Find the crane's rated capacity by dividing the moment rating in Ft.-Lbs. by this load radius in Ft.

Fill out the load radius measured in Step 3 as L in dimensional data listed on the Stability Test Results chart (Drawing 50562).

Calculate the required weight by the formula shown on 50562-A listed as "Correct Weight for 118% Moment"

ALTERNATE METHOD OF CALCULATING LOAD RADIUS USING A KNOWN WEIGHT.

If a know weight is available the load radius can be calculated by:

$$\text{Load Radius, "L"} = 1.18 \times \text{Crane Moment Rating} / \text{Known Weight.}$$

At the calculated load radius the boom elevation should be between 20 and 45 degrees.

Test Procedure:

- 1) With the crane extended over the rear of the truck, lift the load. Always remember to keep the load 1" or 2" off the ground to avoid excessive tipping.
- 2) Slowly begin to rotate the load counterclockwise. Continuously check all vehicle tires to ensure that they are in contact with the test surface.
- 3) Continue to rotate the load counterclockwise until any one of the vehicle's tires break contact with the surface. When any tire loses contact with the test surface, stop rotation. This is the balance point that determines the 85% tipping capacity of the vehicle. Note this point as "Y" on the stability chart ("Y" is the rotation angle the crane was at when tipping occurred).



CRANE STABILITY TEST

- 4) After the balance point has been established, retract or elevate the boom until all tires are in contact with the test surface.
- 5) Once stability has been regained continue to rotate the load counter-clockwise. Remember to continuously check all vehicle tires. When tipping re-occurs, retract the boom until stability is regained.
- 6) Repeat this procedure through a 180° arc or until the vehicle hampers further rotation.
- 7) At the end of the counterclockwise rotation, measure the horizontal distance from the crane center of rotation to the centerline of the load. Record this distance as "L1". "L1" must be the shortest radius encountered during this phase of the test.
- 8) To determine the percentage of full capacity in the de-rated zone beyond the balance point, divide "L1" by "L" and multiply this number by 100. This will yield the percentage of full capacity "W1". This reduction in capacity is necessary to maintain 85% of tipping load.

$$W1 = (L1/L) \times 100$$

- 9) Return the crane to the starting position (extended over the rear of the truck). Repeat steps 1 thru 8 but now rotate the crane clockwise. Record "Z", "L2", and determine "W2".
- 10) Record the necessary vehicle data as listed on the stability chart. Place a copy of this test and the test results in the crane operation section of the owner's manual.
- 11) Stamp or scribe the necessary vehicle data on the "Crane Truck Stability" plate included (P.N.18600). Install the plate in a visible position, preferably on the crane's side plate near the Load Radius Chart.





BY: TV
DATE: 07/07/05

STABILITY TEST RESULTS

OPERATIONAL LIMITS OF CRANE SHOWN BELOW

DOCUMENT NO.
50562-B

VEHICLE DATA

YEAR _____
MAKE _____
MODEL _____
VIN _____

CRANE DATA

MODEL _____
SERIAL NUMBER _____
MOMENT RATING _____
(FT-LBS)

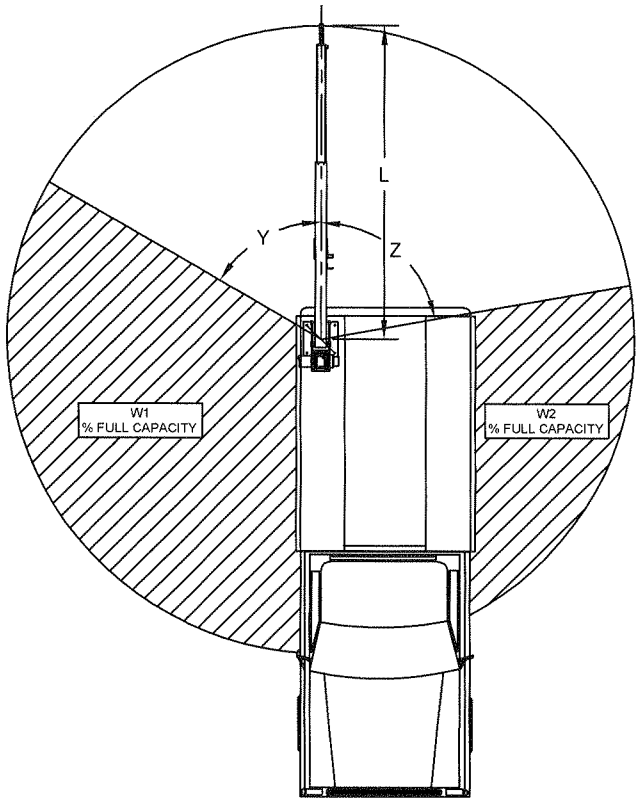

CORRECT WEIGHT FOR 118% MOMENT

TAKE MOMENT RATING (IN FT-LBS) _____
DIVIDED BY LENGTH L (IN FEET) ÷ _____
= _____
MULTIPLY BY 1.18 × 1.18 = _____
WEIGHT REQUIRED FOR TEST

CALCULATE W1

LENGTH L1 (IN FEET) _____
DIVIDED BY LENGTH L (IN FEET) ÷ _____
= _____
MULTIPLY BY 100 × 100 = _____
W1 % RATED CAPACITY

CALCULATE W2

LENGTH L2 (IN FEET) _____
DIVIDED BY LENGTH L (IN FEET) ÷ _____
= _____
MULTIPLY BY 100 × 100 = _____
W2 % RATED CAPACITY

DIMENSIONAL DATA

L _____ FT.
L1 _____ FT.
L2 _____ FT.

STABILITY DATA

Y _____ DEGREES
Z _____ DEGREES
W1 _____ %
W2 _____ %